

Doc No.: VIZA-IOM-TW

Rev No.: 2012

Release No.:

Operation and Maintenance Manual

Welded Body Trunnion Mounted Ball Valves TW Series

Prepared Xiangqing Zhou Date 2012-05-25

Reviewed Yueying Fang Date 2012-05-25

Approved Frank Lu Date 2012-05-25

CONTENTS

1. Forewords
2. Essential health & safety requirements of PED/Atex and solution
3. Application and Technical Parameters
4. Valve Structure
5. Transportation and storage
6. Installation
7. Removal
8. Disassembling Procedure
9. Reassembling Procedure
10. Valve Operation and Maintenance
11. Troubleshooting and Repairs
12. Quality Warrant and Servicing

1. Forewords

Thanks for your selection of VIZA's ball valve. As a type of pressure equipment, valve has potential hazards of pressure and creation of explosive atmosphere resulting from leakage of process fluid. For the safety purpose, user shall read this instruction to know what VIZA has already taken into account in our design and manufacture, and what action shall be taken by user according to essential health and safety requirements of European Directive 97/23/EC (PED) and 94/9/EC (Atex).

2. Essential health & safety requirements of PED/Atex and solution

2.1 What's VIZA design idea:

-Ball valve is designed as standard product, no consideration of each specific service condition since it's too wide.

-Ball valve is designed to API 6D, valve has adequate strength according to ASME B16.34 pressure-temperature rating. The ball valve was EC-type approved by European Notified Body.

-Valve has different sealing materials in accordance with API 6D, which are corrosion/wear resistance to certain type of fluid.

-Valve is designed with anti-static and fire-safety structure. The later one was certified by TUV in accordance with API 607 and API 6FA.

-Valve contains no light metal (such as Mg) and all parts are electricity conductive and connected together to prevent ignite resource.

-Valve is designed with lever, or gear operator or electric actuator according to its size and torque, and operation requirements.

2.2 What action user shall take?

2.2.1 General

2.2.1.1 In any occurrence, first ensure personnel safety.

2.2.1.2 Use the valves in accordance with ASME B16.34 pressure-temperature rating and consider temperature restriction based on non-metal material used on the valve like O-ring and seat inserts.

2.2.1.3 Make sure that the selected valve materials are corrosion/wear resistance to the service fluid.

2.2.1.4 Where the service fluid is flammable/explosive, to limit the working temperature.

2.2.1.5 When performing Repair/maintenance operations, make sure that the valves are always depressurized, vented and drained.

2.2.1.6 For actuator operated valves, make sure all supply lines (Electrical, hydraulic, Air) are

disconnected before starting any Repair/maintenance operations.

- 2.2.1.7 When performing Repair/maintenance operations, always use appropriate protection e.g. protective clothing, (oxygen) masks, gloves, etc.
- 2.2.1.8 When performing Repair/maintenance operations, do not smoke, do not use any portable no-Ex-proof electrical device in the area and do not use open fire without a valid work permit.
- 2.2.1.9 Valve must be periodically checked on:
 - Tightness of bolted connection (body/closure, gland, flange connection).
 - Corrosion/wear damages (crack, pitting, thickness of the valve).
 - Make sure the valves are in fully open/fully closed position.

2.2.2 Specifics

Risk	Preventive Action
Accidental contact with dangerous service fluid* Due to: Gasket or Stem Blow out	1. See 2.2.1 General
	2. Immediately replace Gasket and packing after a Blow-out (use approved/suitable materials only)
	3. Use recommended torque as in Table 1
Accidental contact with dangerous service fluid* during disassembly or maintenance operations	1. See 2.2.1 General
	2. After removal from the production line, open and close valve to guarantee depressurized cavity.
	3. Drain any remainder fluid or substances with suitable devices before disassembly.
Structural yielding of valves body with consequent risk of contact with dangerous service medium*, explosion or fire	1. See 2.2.1 General
	2. Create precautions to avoid additional forces on the valves
	3. Avoid absolutely water hammer: install precaution devices if necessary (e.g. brakes, anti shock devices, etc.)
	4. Avoid submitting excessive vibrations to the valves.
	5. Avoid quick Pressure and/or Temperature change impact.

Accidental contact with High or Low temperature parts	1. See 2.2.1 General
	2. Predispose apposite insulation on the valve.
	3. Alert by means of warning signs about risk of burns.
	4. For Cryogenic service use only valves equipped with Cryogenic Extension.
Fire or explosion in case of service with flammable fluids	1. See 2.2.1 General
	2. Install only Ex-proof electrical devices in the area
	3. While performing maintenance in the area, shut down all electrical devices.
Explosion in case of oxygen service	1. See 2.2.1 General
	2. Install only Ex-proof electrical devices in the area
	3. Install and use only valves completely degreased.
	4. Use valves only made with materials suitable for oxygen service (see EN 1797-1)

* Dangerous service fluid as there are: Toxic, Corrosive, Flammable, High or Low temperature etc. fluid.

3. Application Scope and Technical Parameters

3.1 Application scope

This series valves are widely used in petroleum, gas, chemical, and allied industries for normal operation of pipeline system.

3.2 Technical Parameters:

Nominal pipeline size:	2~40"
Nominal pressure:	150~2500LB
Temperature range:	≤300°F
Fluid:	Water, oil, gas and other kinds of fluid
Body material:	Material as specified in ANSI B16.34
Valve testing::	API 6D
Actuator:	Gear, Lever, motor
Applicable ATEX:	 II 2 GD c

4. Valve Structure

Please refer to Fig 1 and Fig 2 for valve structure. (SS overlay on seat pocket area available when required)

Drawing for 4" and below (Fig 1)

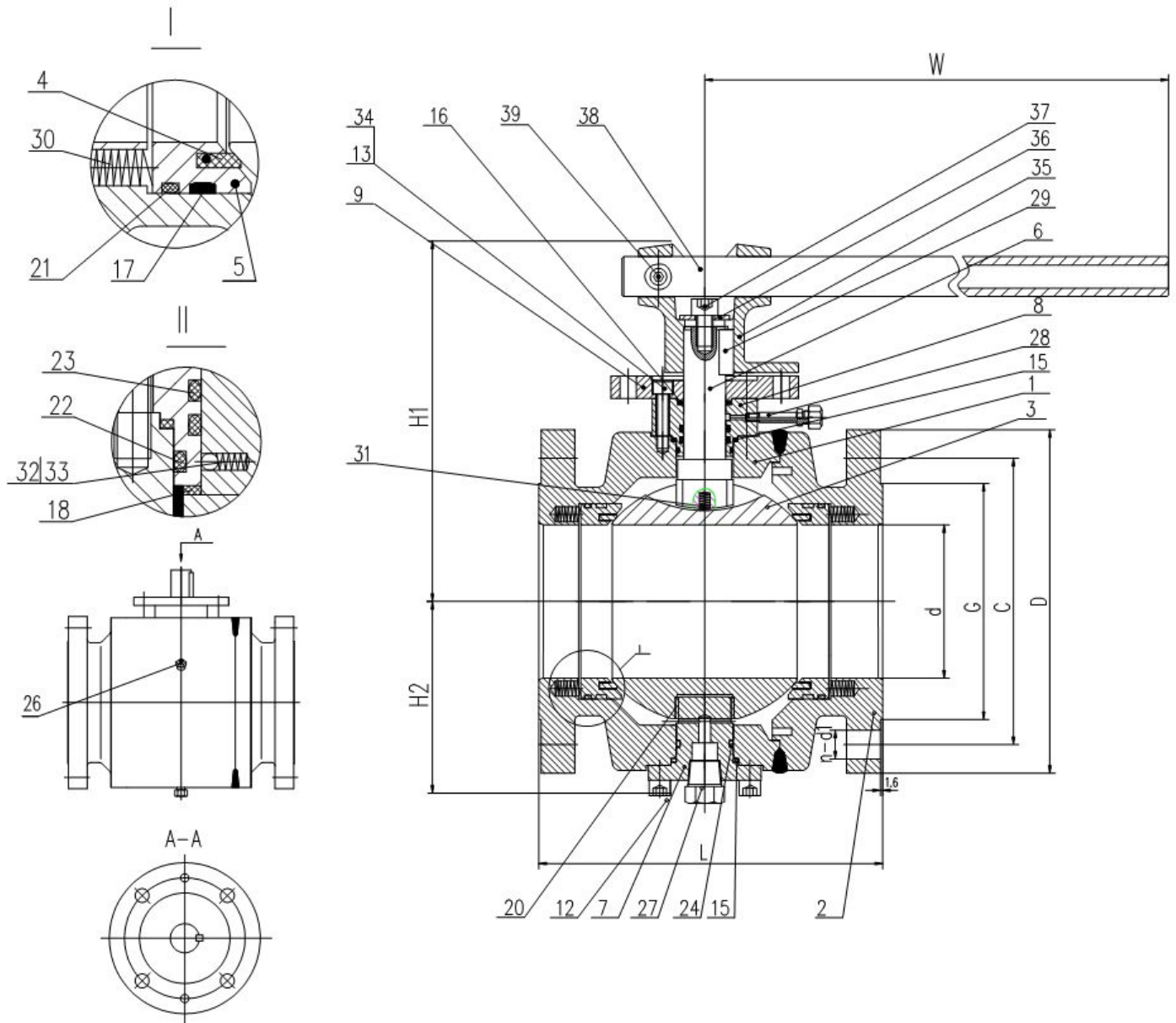

Fig 1

Drawing for 6" and large (Fig 2)

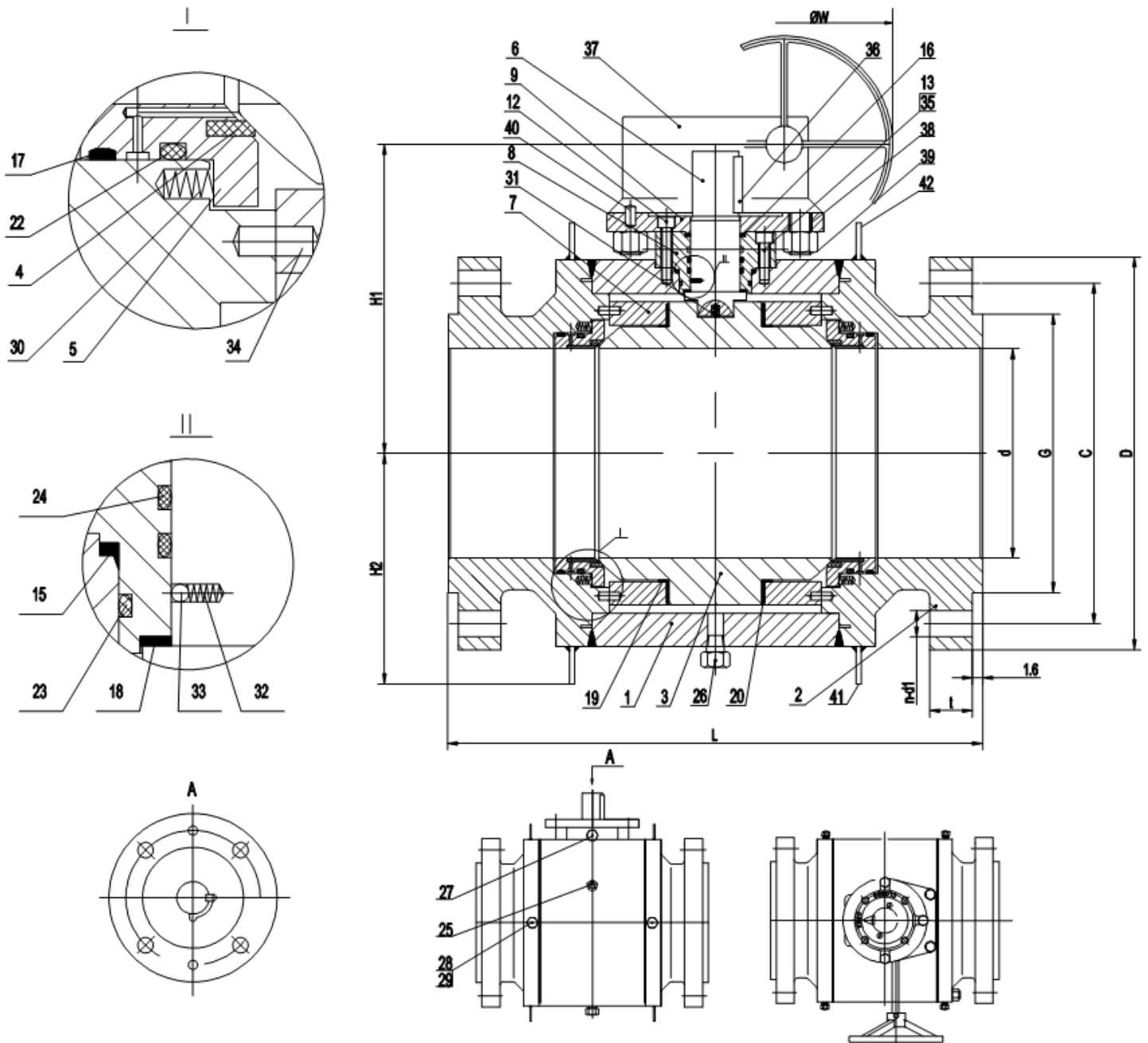

Fig 2

4.1 Main Parts

No.	Parts name		No.	Parts name	
	Fig.1	Fig.2		Fig. 1	Fig. 2
1	Body	Body	22	Gland O-ring	Seat O-ring
2	Adapter	Adapter	23	Stem O-ring	Gland O-ring
3	Ball	Ball	24	Trunnion shaft O-ring	Stem O-ring
4	Seat insert	Seat insert	25		Vent Valve
5	Seat ring	Seat ring	26	Vent Valve	Drain Plug
6	Stem	Stem	27	Drain Plug	Stem injection
7	Trunnion shaft	Trunnion Support	28	Stem injection	Seat injection
8	Gland flange	Gland flange	29	Stem Key	Inner Check
9	Top flange	Top flange	30	Seat spring	Seat spring
10			31	Antistatic spring	Antistatic spring
11			32	Antistatic spring	Antistatic spring
12	Screw	Screw	33	Grounding plunger	Grounding plunger
13	Screw	Screw	34	Gland pin	Alignment pin
14			35	T head	Gland pin
15	Gland gasket	Gland gasket	36	Washer	Key
16	Stem firesafe packing	Stem firesafe packing	37	Screw	Gear
17	Seat firesafe packing	Seat firesafe packing	38	Pipe Lever	Stud
18	Thrust washer	Thrust washer	39	Screw	Nut
19		Washer	40		Gear Pin
20	Bearing	Bearing	41		Supporting Leg
21	Seat O-ring		42		Lifting lug

4.2 Working Principle

The function of the ball valve is to cut off or put through the pipeline. When the ball is driven by the wrench or other actuator, it rotates and the bore of ball parallelized or perpendicular with the bore of body, the valve opens or closes.

4.3 Structure Description

4.3.1 This series ball valve uses seat insert seal structure. PTFE or NYLON is used as the seat insert material, The “O” ring is used as the stem and seat ring seal, and the material is in HNBR or VITON. In the event of fire, when all the soft seals are burned, ball valve has second fire-safe sealing areas such as:

Metal-to metal contact between ball and seat ring;

Graphite seal between seat and body;

Graphite seal between body and closure;

Graphite seal between stem and body;

For accidental leakage from the stem sealing area, a sealant injection is provided; leakage can be temporarily prevented by injection of the sealant into this mechanism.

4.3.2 Ball/seats shut off the line fluid independently on the upstream and downstream side of the ball, the valve bore and the body cavity are isolated from each other when the valve is fully opened or closed.

4.3.3 The lower end of the stem is designed with an integral collar to be blowout-proof.

An antistatic feature is provided to ensure electrical continuity between ball, stem and body.

4.3.3 Body to Adapter joint type is welded connection to reduce leakage from body to adapter joint type.

5. Transportation and storage

5.1 Transportation

5.1.1 When carrying the units in unpacked conditions (in a dusty place), put a plastic sheet over them.

5.1.2 Load the units so that no force is placed on the actuator.

5.1.3 Avoid overloading the unit: the cargo may become loose; take care so that the valves do not bounce.

5.1.4 Always handle the valve with care, use lift equipment for the large size valves.

5.2 Storage

5.2.1 When the units are not used for a while after received, store it under conditions where no unnecessary force is applied.

5.2.2 When storing the unit in unpacked conditions, take care so that no dust, dirt or oil-intrudes into the unit.

5.2.3 When storing the unit either temporarily or for a long period of time, avoid direct sunlight. Always store the unit indoors at dry place and flange sealing surface protected.

5.2.4 Always store valve in open position.

- 5.2.5 Long-time-stored valve shall be re-inspected prior to use. Close attention shall be paid against sealing damage when removal of dirties for the cleanness of sealing surface. If necessary, valve shall be pressure tested once more.

6. Installation

- 6.1 Carefully check valve identification against operation requirements before installation.
- 6.2 Check the inside of bore and the sealing surface before installation, any attached dirty and contamination shall be removed with clean soft cloth.
- 6.3 Check the sensibility of actuator to prevent block before installation.
- 6.4 After the valve is located in the center of the piping, tighten the bolts diagonally.
- 6.5 Never weld the piping flange with the valve installed, never install the valve immediately after welding.
- 6.6 Never operate valve with a wrench or lever applied to the actuator.
- 6.7 Partial tightening of the piping bolt is not allowed.
- 6.8 Avoid forcing the valve between the piping flanges.
- 6.9 Always maintain a space for easy checkup and repair.
- 6.10 When in service, valve must be fully opened or fully closed. It is forbidden to partially open the valve for adjustment of flow rate.
- 6.11 Dust, grease and fluid residual trend to accumulate at the surfaces of body and stem etc, wear and erode the valve, and shall be cleaned frequently.

7 Removal

- 7.1 When removing the valve from the piping, check that: the pressure and fluid do not remain inside the piping.
- 7.2 When removing the valve, lift the valve with soft rope which shall be strong enough to subject the valve weight.

8. Disassembling Procedure

When disassembly of the valve is required (for example for periodical checks or sealing parts replacement), refer to the structural drawing and do the work according to the following procedure.

- 8.1 For gear operator or power actuator valve
- a) Remove the bolt fastening the gear body or power actuator
 - b) Remove the gear operator or power actuator
 - c) For subsequent operation, follow the disassembling procedure for the top flange

- 8.2 For "T" type head operator
 - a) Remove the screw fastening the lever pipe
 - b) Remove the lever pipe
 - c) Remove the screw fastening the T head
 - d) For subsequent operation, follow the disassembling procedure for the top flange
- 8.3 For top flange
 - a) Remove the screw fastening the top flange
 - b) With a bronze hammer striking lightly the top flange, then lifting off the top flange
 - c) Remove the pin on the gland flange
- 8.4 For gland flange
 - a) Remove the screw fastening the gland flange
 - b) Lifting off the stem and the gland flange
 - c) Remove the stem from the gland flange
 - d) Check the O-ring ,bearing and gasket on the gland flange for any damage
 - e) Remove the stem injection(if installed)
 - f) For subsequent operation, follow the disassembling procedure for the trunnion shaft (apply for size 4" and below)
- 8.5 For trunnion shaft (for size 4" and below)
 - a) Remove the screw fastening the trunnion
 - b) Lifting off the trunnion
 - c) Remove the vent valve from the trunnion
 - d) Check the O-ring , bearing and gasket on the trunnion for any damage
 - e) For subsequent operation, follow the disassembling procedure for the closure

9. Reassembling Procedure

Reassemble all parts after cleaning, before re-assembling, refer to the structural drawing, and check that all parts are completely prepared, It is recommended that bearing, O-ring, gasket should be replaced even when not damaged.

- 9.1 For trunnion Plate (for size 6" and above)
 - a) Put the bearing into the trunnion plate
 - b) Put another bearing into another opposite trunnion support
 - c) Install the ball between both support
 - d) Put the ball and trunnion support into the body and make sure the pin insert in the trunnion plate
- 9.2 For trunnion shaft (for size 4" and below)

- a) Install O-ring and gasket on the trunnion shaft
 - b) Install vent valve
 - c) Put the trunnion shaft through the bottom hole of the body and insert in the bottom hole of the ball, make sure the ball rotate freely
- 9.3 For gland flange
- a) Put the O-ring and gasket on the gland flange
 - b) Install stem injection(if applicable)
 - c) Put the stem through the hole of the gland flange
 - d) Put the stem through the top hole of the body and insert in the top groove of the ball
 - e) Put the pin into the top hole of the body
 - f) Install the gland flange and tightening the screws
- 9.4 For top flange
- a) install top flange and tightening the screws
- 9.5 For gear operator and power actuator
- a) Install key on the stem
 - b) Install gear operator and power actuator on top flange and tightening the bolts
- 9.6 For "T" type head operator
- a) Install the key on the stem
 - b) Install T head on the stem
 - c) Install the washer in the T head and tightening the screw
 - d) Install lever pipe
 - e) tightening the screw to fix the lever pipe
- 9.7 Install vent valve, drain valve and seat injection (if need)
- 9.8 This completes the reassembly

10. Valve Operation and Maintenance

- 10.1 After installation and the pressure test of the pipeline or the system, the ball must be fully opened or fully closed. It is forbidden to partially open the valve for adjustment of flow rate or emergent pressure relief blow-off. VIZA is not responsible for damage, loss or expense arising out of such usage.
- 10.2 Usually ball valves do not set up heat insulation structure, never touch the surface of valves when the process fluid has a high/low working temperature.
- 10.3 Dust, grease and medium residual trend to accumulate at the surfaces of body, and moving parts such as stem, gearbox, the guide of yoke etc., wear and erode the valve, and even generate friction

heat that is dangerous in explosive atmosphere, and shall be cleaned frequently according to the working conditions.

- 10.4 The thickness of body and closure must be checked to ensure safety operation at an interval of three months. Where the thickness is less than value in Table10, the valve must be scrapped.
- 10.5 After put into service, valve shall be checked and maintained periodically especially for the situation of sealing surfaces and worn, the age of packing and the corrosion of body. In case of such situation, valve shall be repaired or replaced. It is suggested that inspection and maintenance of valve shall be perform every three months provided the fluid is water or oil, every month or to local law provided the fluid is strong corrosive.

Table 2 Body minimum wall thickness

	20bars 150lb	50bars 300lb	100bars 600lb	150bars 900lb	250bars 1500lb	420bars 2500lb
DN50(2")	5.5	6.0	6.2	7.8	11.8	19.6
DN65(2-1/2")	5.8	6.5	7.2	9.3	14.5	24.7
DN80(3")	6.1	7.0	8.2	10.9	17.3	29.8
DN100(4")	6.5	7.7	9.5	13.0	21.0	36.6
DN150(6")	7.1	9.4	12.9	18.2	30.2	53.7
DN200(8")	8.0	11.0	16.3	23.4	39.4	70.7
DN250(10")	8.8	12.7	19.7	28.7	48.6	87.8
DN300(12")	9.6	14.3	23.0	33.9	57.9	104.8
DN350(14")	10.4	16.0	26.4	39.1	67.1	121.9
DN400(16")	11.2	17.6	29.8	44.3	76.3	138.9
DN450(18")	12.0	19.3	33.2	49.6	85.5	155.9
DN500(20")	12.9	20.9	36.5	54.8	94.8	173.0
DN600(24")	14.5	24.2	43.3	65.2	113.2	207.1
DN700(28")	16.1	27.5	50.0	75.7	131.6	241.2
DN750(30")	16.9	29.2	53.4	80.9	140.9	258.2
DN800(32")	17.7	30.8	56.8	86.1	150.1	275.3
DN900(36")	19.4	34.1	63.5	96.6	168.5	309.4
DN1000(40")	21.0	37.4	70.3	107.0	187.0	343.5

- 10.6 After reparation, valve shall be re-assembled and adjusted using recommended torque as listed in Table 1. After reassembly, valve shall be pressure tested.
- 10.7 When performing Repair/maintenance operations, user shall use valve O-ring, gasket, bolt and nut

of the same size and material as the original one. Valve O-ring and gasket may be ordered as spare parts for maintenance and replacement. It is forbidden to open the closure or replace the bolt, nut or O-ring when the valve contains pressure. After replacement of O-ring, gasket, bolt and nut, valve shall be closure test prior to reuse.

- 10.8 Generally valve trim prefers replacement to reparation. It is better to use provided part as replacement. If part produced by valve manufacturer is not available due to emergency, user shall produce the part to VIZA's technical documentation. VIZA takes no responsibility for loss caused out of part produced other than VIZA.
- 10.9 It is not recommended for reparation of valve pressure-containing part by user. If the pressure-containing part is used for a long time and consequently defection occurs and affect safety use, user shall replace the valve with a new one.
- 10.10 Welding repair on valve online is forbidden.
- 10.11 The online valve shall not be knocked, walked on or used as weight support.

11. Troubleshooting and Repairs

Trouble	Probable Cause	Remedy
Hard to operate	<ol style="list-style-type: none"> 1. Actuator unit 2. Infrequent operation lack of lubrication 3. Ice in operator or valve 4. Stem galling 	<p>Remove actuator cover and check screw and linkage for damage.</p> <p>Lubricate seats through the injection and actuator with suitable industrial lubricants</p> <p>Apply heat or inject antifreeze solution.</p> <p>Repair or replace the stem.</p>
Leakage from sealing	<ol style="list-style-type: none"> 1. Dirties between sealing surfaces 2. Sealing surface damaged. 	<p>Clean out the dirty.</p> <p>Repair the Sealing surface or change seat insert.</p>
Leakage from stem	<ol style="list-style-type: none"> 1. "O" ring failure due to used-up or improper storage 2. Stem sealing damaged. 	<p>Replace with new "O" ring</p> <p>Check the stem when maintain the pipeline, repair or replace the damaged stem.</p>

Not able to fully close	Improper setting of actuator limit switches or stops in worm gear actuator	Reset limit switches or stops for proper closing
Grease fitting leaking	Inner check not tight or damaged	Tighten or replace inner check, Do not remove inner check fitting while pressure is in-line
Restriction in bore of valve	Ball not properly aligned with bore of seat	Check proper setting of worm gear actuator and/or actuator limit switches.

12 Quality Warrant and Servicing

12.1 Quality Warrant

12.1.1 VIZA warrants its valves to the original purchaser for a period of 18 months from and after the date of delivery to the original customer, or 12 months from startup which occurs first, against defects in material and workmanship under proper and normal use and service and not caused of resulting from improper application or usage, improper installations, improper maintenance and repairs, modifications or alterations.

12.1.2 Purchaser shall give notice in written to VIZA upon finding of any defect or assuming defect, VIZA has privilege to check the facts of the defect.

12.1.3 VIZA sole obligation under this warranty shall be limited to the follows:

- Repair of the material,
- Replacement of the parts and materials,
- refund the purchase price and collect the defected products from the original purchaser.

12.1.4 VIZA is not responsible to claims caused from unexpected natural disaster such as earthquake, typhoon of any kinds arising out of the defect.

12.1.5 The scope and limitation of warranty can be changed on the agreement between VIZA and purchaser.

12.2 Servicing

Where contractually specified, the manufacturer may provide field installation and adjustment.